

Table of contents

Warnings	2
Introduction	3
General view and pinout	4
Basic specifications	6
Functionality	7
Operating principle	7
Available use cases	8
1. Original internal battery + additional external battery	8
2. Single original internal battery	8
3. Single external battery	8
4. Custom internal battery + additional external battery	8
5. Single custom internal battery	8
External battery connection	9
Distribution of current consumption between batteries	9
Displaying current charge level	9
Battery Charge	10
Recovery current protection	10
Using 12s+ batteries	12
Installation	13
Wiring sequence	13
Installation process video tutorial	14
Setting up the device	15
Description of parameters	16
Default parameter values	16
Troubleshooting	17
Warranty and technical support	18

Warnings



WARNING!

Lithium-ion batteries are very dangerous! Improper use of this equipment may cause a fire.



WARNING!

Use of this equipment requires at least basic knowledge in electronics and electrical engineering.



WARNING!

When installing this equipment, read and follow the manufacturer's instructions exactly.

Introduction

Here is the “Universal adapter for additional external battery hot-plug connecting” or, in short, Rita.

The first key feature of the device is the ability to connect and disconnect an additional battery at any time, regardless of its charge level and the charge level of the internal battery. It is not necessary to align the battery voltage before connecting an additional battery.

The second key feature of the device is that the additional battery can be not only more charged and have higher voltage because of this, also it can even have a higher voltage configuration, for example 12s or 15s, which can significantly increase the scooter speed, up to 45 km/h

General view and pinout

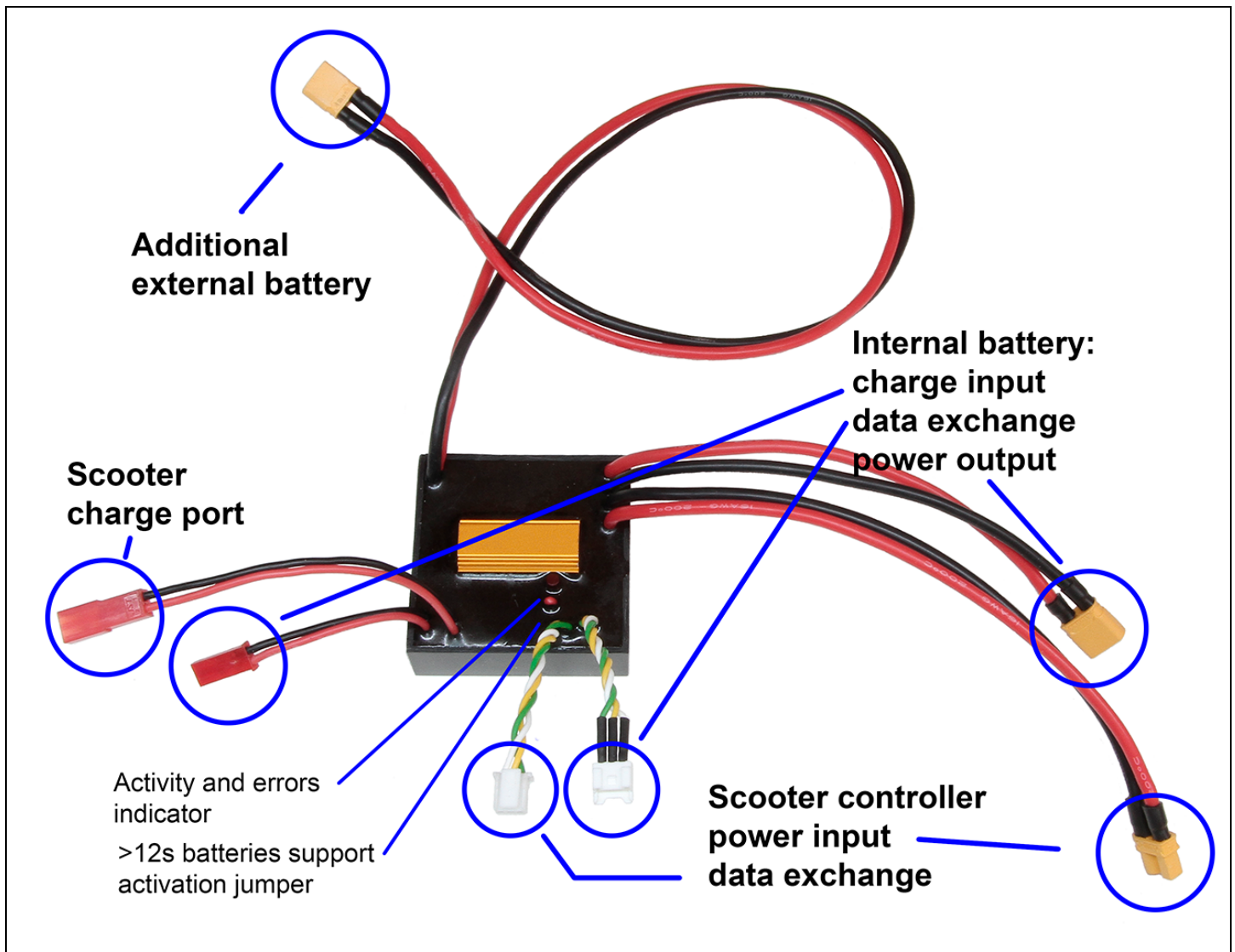

Additional external battery	Pull out of the scooter, connect an additional external battery to this plug.
Scooter charging port	Connect to the charging port of the scooter.
Internal battery: charging input	Connect to the charging port of the internal battery.
Internal battery: data exchange	Connect to the data exchange port of the internal battery.

(continued on the next page)

General view and pinout(continuation)

Internal battery: power output	Connect to the power output of the internal battery.
Scooter controller: power input	Connect to the power input of the scooter controller.
Scooter controller: data exchange	Connect to the data exchange input of the scooter controller.
Activity and error indicator	<p>Blinks a short flash once every 2 seconds when the scooter is turned off and the device is in power saving mode.</p> <p>Blinks a short flash twice a second when the scooter is turned on, and there is an active data exchange with the controller.</p> <p>Glows continuously if there was an emergency voltage surge during energy recovery, until the error will be automatically reset by timeout.</p>
Jumper to activate support of 12s+ batteries	<p>This jumper must be cut off in order to be able to use batteries with voltages more than 51V. DO NOT CUT THIS JUMPER OFF IF THE SCOOTER CONTROLLER IS NOT MODIFIED FOR AN INCREASED VOLTAGE!</p>

Basic specifications

Supported Battery Types	Li-ion, Li-pol
Supported Battery Configurations	10 - 15s*
Maximum possible capacity of an additional battery	No limits
Maximum continuous total discharge current of internal and external batteries, A	30
Maximum continuous total charge current of internal and external batteries, A	10
Self-consumption of battery current, mA	2

*Installation of batteries with a voltage of more than 51V(12s) requires modification of the main scooter controller, as well as the special connection of this adapter. 12s batteries may be used without controller modification and with regular connection of the adapter.

Functionality

Operating principle

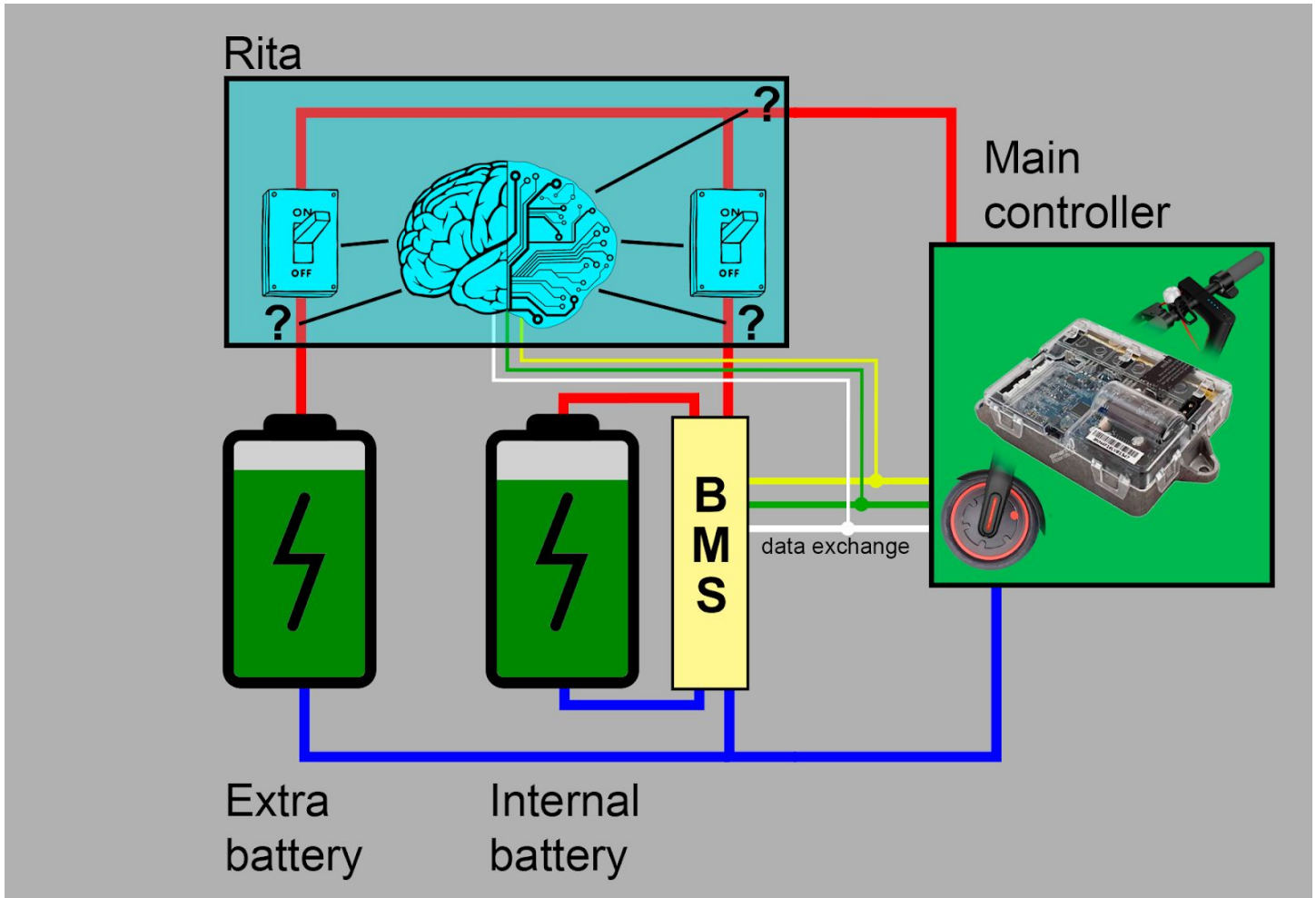

Rita analyzes the voltages of the internal and additional external batteries, and switches their positive power leads so that the charge does not flow from one battery to another, at the same time keeps the ability for the controller to consume current from both batteries and recover energy back when braking.

Besides the commutation of power leads, Rita also takes control of the data exchange lines, and can either transparently pass the exchange between the main controller and the internal battery, or completely replace the exchange, blocking the data flow from the internal battery.

Available use cases

Due to the fact that Rita has full control over power lines and data exchange lines, it provides a wide choice of use cases:

1. Original internal battery + additional external battery

The main case, for which the device was created. The scooter gets an increase in range, as well as an increase in maximum speed, if the additional battery has a higher voltage. Due to the hot plug feature, there is an opportunity to leave the scooter outside, taking only an external battery for recharging.

2. Single original internal battery

In this case the external additional battery is not connected, and the scooter is powered by the original internal battery only. This option is useful to go somewhere nearby. Of course, the range and maximum speed are like a scooter out of the box

3. Single external battery

This case is suitable, for example, if the original battery is broken. Another feature is that the battery can be taken off to carry the scooter by plane.

4. Custom internal battery + additional external battery

This option is very similar to the first one. The difference is that inside is not the original battery, but the custom one, which was installed there to change the broken one, or to increase the capacity / voltage. The feature is that there is no need to use a specialized smart bms for this custom battery - in fact, the device performs as a smart bms emulator, in addition to its main function of connecting an additional battery. To use this mode, you need to change the "Mode" setting in the "Permanent BMS emulator". As in the first case, due to the hot plug feature, there is an opportunity to leave the scooter outside, taking only an external battery for recharging.

5. Single custom internal battery

The same as the previous option, but without an external additional battery. Here Rita operates as a smart bms emulator. To use this mode, you need also change the "Mode" setting in the "Permanent BMS emulator".

External battery connection

The additional external battery is connected only with two power wires, without any data lines.

On the one hand, this is convenient because the additional battery may be equipped with the cheapest common port bms.

On the other hand, we don't have information about its current state, for example, the temperature or voltage of each parallel. Therefore, in place of this data, just static numbers are displayed: the temperature is always shown at 20 degrees, and the voltage of the parallels is calculated by simply dividing the total battery voltage by its configuration. The current consumption could be measured, but in order to reduce the cost, it refused, so the current and power are displayed as zero.

Distribution of current consumption between batteries

If the internal and external batteries have different voltage levels, firstly the current will be consumed from the higher voltage battery, and then, when the voltages are aligned, the current will be consumed from both batteries almost equally.

Displaying current charge level

When calculating the level of the remaining charge, Rita generally does not consider the capacity and configuration of the additional battery, assuming that only the internal battery is connected. Example:

Additional voltage 12s batteries (and its charge level)	Main Battery Voltage 10s (and its charge level)	Displayed charge
50V(100%)	38V(60%)	100%
45V(70%)	38V(60%)	100%
42V(50%)	38V(60%)	100%
40V(30%)	38V(60%)	80%
38V(10%)	38V(60%)	60%
36V(0%)	36V(50%)	50%
0V(0%)	33V(20%)	20%
0V(0%)	30V(0%)	0%

A very notable moment is highlighted in red: in fact, just over 50% of the total charge of both batteries remains, but the scooter displays 100%. It's not convenient, but you can get used to it. This simplification of functionality is also made to reduce the cost of the device.

Battery Charge

Rita allows you to charge the external and internal batteries simultaneously through the standard scooter charge port. That is, you don't need a special charging port at the external battery, or take it off for charging. Just plug the charger into the standard port of the scooter and both batteries will be charged.

If the extra battery with increased voltage is used, a new charger with increased voltage is needed. Use the new charger as usual - just plug it into the scooter charge port and the BMS of the internal battery will stop charging when it reaches 42V, while the additional battery will charge up to 50V.

Recovery current protection

When connecting any battery to the Xiaomi M365, you have to remember that the scooter not only consumes current from the battery during acceleration, but also returns the charge back when braking by energy recovery. For the correct operation of the recovery system, the battery must to:

1. Receive the recovery current, which flows from the controller to the battery.
2. Or, if the battery is already fully charged and cannot receive the recovery current, inform the controller to stop the recovery in advance, using the data lines.

If the battery suddenly stops receiving the recovery current without notifying it in advance, this leads to a surge of voltage and the scooter controller burn out.

When using an additional battery, the problem is that the external battery is connected with only two power wires, and it does not have any data lines to notify the controller in advance that it no longer receives the recovery current.

To solve this problem, Rita uses as many as 2 subsystems: primary and emergency.

The primary subsystem operates like this. Rita continuously measures the voltage of the external battery, then divides it by the serial configuration of the battery, resulting in the average voltage of the parallel. For example, if the voltage of the external battery is 48 V, and its serial configuration is 12s, then the calculated parallel voltage is approximately 4 V. When using a high-quality balanced battery, this approximate calculation is quite accurate.

Further, after calculating the average parallel voltage, Rita compares it with the voltage of BMS charge prohibition. This voltage is a configurable parameter, the default value is 4.1 V. If the calculated average voltage of the parallels is higher than the energy recovery prohibit voltage, Rita informs the controller via the data line about the need to stop the energy recovery, thus the recovery system works correctly and the battery never closes unexpectedly for the controller.

But the main subsystem may fault if the battery is out of order, exactly: if the parallels are very unbalanced. Consider an example: all parallels in a battery have a voltage of 3.6 V, and one of them - 4.2 V. BMS prohibits charging, and that is completely right, but Rita, as usual, measures the battery voltage: $3.6 * 11 + 4.2 = 43.8$ V, after that it is divided by 12, having calculated an average parallel voltage of $43.8 / 12 = 3.65$ V, and informs the controller that everything is fine and can be recovered. As a result, since the recovery current has nowhere to go, and it continues to flow, the voltage of the controller rises up. And the burn out would be immediately, if there wasn't the second subsystem - the emergency.

The emergency subsystem analyzes the voltage at the output of the device, and if it exceeds a critical level, it detects the main subsystem fails, and it is urgent to save the controller. First of all the emergency subsystem immediately sends a command to the controller to stop the recovery, but it is not enough: it takes about 100 milliseconds to execute the command, during which the recovery currents have enough time to burn everything in its path. Therefore, all the time, until the command is executed, the emergency subsystem drains excess voltage to a powerful 25-watt resistor, keeping the voltage within safe limits.

When the emergency subsystem is triggered, Rita intercepts the data exchange and sets the temperature sensor to 100 degrees, which causes the scooter to start beeping error 39, drawing the attention of the owner to the malfunction.

The general conclusion about energy recovery: don't worry, everything will work fine, and nothing will burn out, just follow a number of simple rules.

- 1. Use high-quality batteries which do not disbalance by itself because of the variation in cell characteristics.**
- 2. Install a BMS with balancing function in the battery. Check if the charger voltage is sufficient to activate balancing.**
- 3. Watch the behavior of your battery: if it starts to discharge and charge too quickly, or the range suddenly decreased, it makes sense to check if everything is okay with it. At least check the voltage on each parallel for disbalance.**
- 4. Correctly set the parameter responsible for the energy recovery disable voltage level. The default value of 4.1 V is optimal.**
- 5. Correctly set the parameters that are responsible for the serial configuration of the batteries.**

Using 12s+ batteries

The main controller withstands a continuous supply voltage up to 51 V, as well as short voltage surges up to 60 V.

Therefore, the emergency protection subsystem, which was mentioned above, is configured by default to a threshold of 57 V. This ensures that if the recovery system fails, the voltage on the controller does not exceed the critical level and it will not be damaged.

However, 15s batteries in fully charged state have a voltage of 63 V, so if you connect such a battery, Rita decides that the recovery has failed, and tries to reduce the voltage to 57 V. It leads to almost instantaneous overheating and explosion, because the built-in resistor is designed only for short-time absorption of recovery currents that last no longer than 100 milliseconds.

Especially for those users who have modified their controller for higher voltages, Rita allows you to raise the emergency protection threshold from 57 V to 67 V. To do this, cut off the red wire-jumper located next to the LED indicator. After this, the use of 15s batteries becomes available, but it is forbidden to use a controller that is not modified for increased voltage, because in case of a failure during the recovery, the protection will be activated too late for it.

Changing the emergency protection threshold is specially made in the form of an inconvenient cutting of the wire so that the user thinks carefully before doing this, and not thoughtlessly changes the settings on the smartphone screen.

Do not forget this:



ATTENTION!

Installation of batteries with a voltage of more than 51V(12s) requires modification of the main scooter controller, as well as the special connection of this adapter. 12s batteries may be used without controller modification and with regular connection of the adapter.

Installation

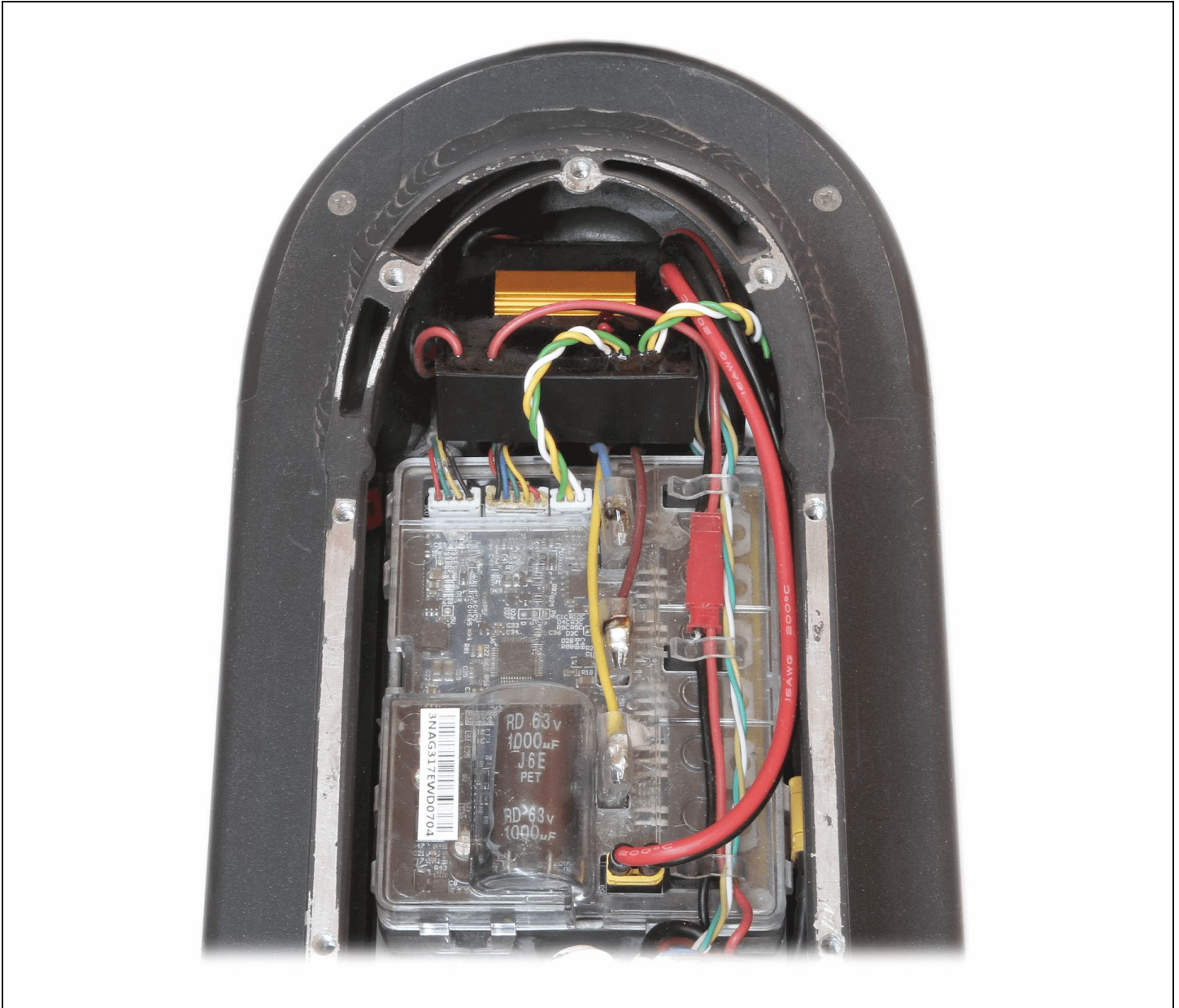

Wiring sequence

1. Disconnect the built-in battery: power output, charging input, data line.
2. Bring out the plug for connecting an additional external battery.
3. Connect the charging port of the scooter to the adapter.
4. Connect the power output of the internal battery to the adapter.
5. Connect the charging input of the internal battery to the adapter.
6. Connect the internal battery communication connector to the adapter.
7. Connect the adapter data connector to the scooter controller.
8. Connect the power output of the adapter to the scooter controller.

Installation process video tutorial

[Xiaomi M365/PRO/1S extra battery
installation tutorial](#)



Setting up the device

Please, use the “M365 BMS Tool” application to configure the device:

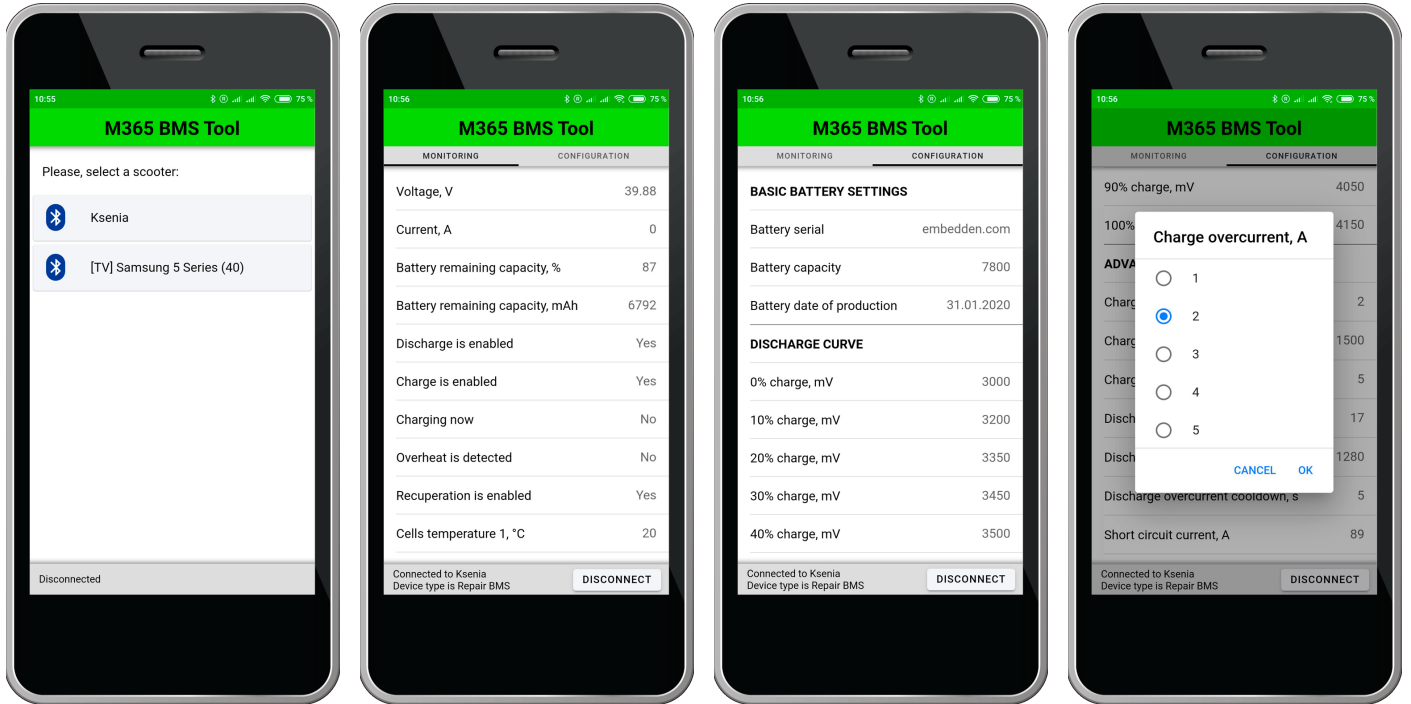

[Download for Android](#)



[Download for iPhone](#)

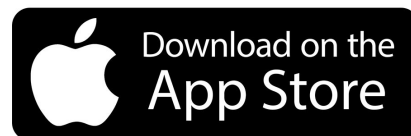
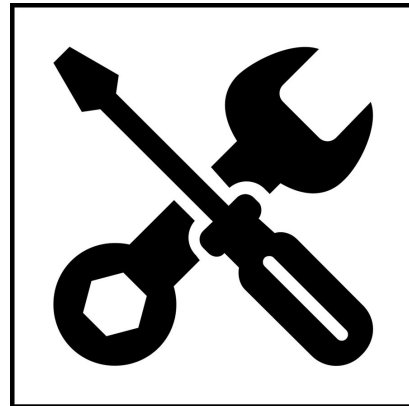

Description of parameters

<i>Parameter</i>	<i>Description</i>
Mode	<p>Sets the adapter operation mode, two options are available</p> <ol style="list-style-type: none"> 1. External battery. In this mode: <ol style="list-style-type: none"> a) If the voltage of the internal battery is greater than the voltage of the additional battery (or the external battery is not connected at all), Rita transparently passes the data exchange between the internal battery and the controller. b) If the voltage of the additional external battery is greater than the voltage of the internal battery, Rita blocks the data flow from the internal battery, replacing it with information about the external battery and simulating the behavior of a smart BMS. 2. Permanent BMS emulator. In this mode, Rita constantly simulates the behavior of a smart BMS. This mode can be useful if you use a custom built-in battery without a smart BMS.
Internal battery capacity, mAh	Built-in battery capacity. This value is displayed in applications when using the “Permanent BMS emulator” mode
Internal battery configuration	Built-in battery configuration. A very important parameter, used primarily to calculate the moment when it is necessary to prohibit the energy recovery
External battery configuration	Additional battery configuration. A very important parameter, used primarily to calculate the moment when it is necessary to prohibit the energy recovery
Recuperation off cell voltage, mV	If at least one battery parallel voltage is higher than this value, a command to prohibit the recovery is sent to the controller.

Default parameter values

<i>Parameter</i>	<i>Default value</i>
Mode	External battery
Internal battery capacity, mAh	7800
Internal battery configuration	10
External battery configuration	10
Recuperation off cell voltage, mV	4100

Troubleshooting

Problem:

The scooter does not brake with an electronic brake.

Solution:

1. If the batteries are almost fully charged, this is normal. Typically, a few accelerations are enough to reduce the voltage slightly, after which the energy recovery and electronic braking function again.
2. If the energy recovery and the electronic brake do not work, although the batteries are obviously not overcharged, please check the settings: firstly, if the internal and external battery configurations are set correctly and matches the used batteries - these parameters are named "Internal battery configuration" and "External battery configuration", and also check the threshold of the energy recovery prohibition - "Recuperation disable cell voltage", the default value is 4100, and it is acceptable in most cases.

Problem:

Scooter does not brake with electronic brake and beeps error 39.

Solution:

This behavior usually indicates a battery problem. For more details, see "Functional Description -> Protection against Recovery Currents".

Warranty and technical support

The warranty period is valid for 1 year from the date of the original purchase.

If you did not find the answer to your question after reading this manual, please, feel free to ask your questions in the special telegram group:

[Xiaomi M365/PRO/1S custom electronics](#)
by Denis Yurev

